



RULEBOOK 2023

Last updated 2023-04-01

This rulebook is an official document of the International Slot Racing Association (ISRA). It is updated based on decisions by the ISRA national delegates. It is checked and published by the elected ISRA officials.

It is updated at the latest 30 days after an ISRA Delegates decision on a rule change.

Definitions

The ISRA World Championships (ISRA WC) is defined as the whole event including practice sessions, meetings and four races.

A race is defined as a competition measured from the beginning of the technical inspection until the end of the final stage of that competition. The ISRA WC consists of four races.

A class is defined as a technically specified car to be used. A race always runs one class only. Qualifying, warm-up, heats, semi-finals and the final are seen as stages of a race.

Group/groups are used as the division of a stage following the results of qualifying or earlier stages of the race.

A segment is defined as one of eight time periods of driving in a group.

An entrant is a person who has enrolled, paid the entry fee and ISRA license, and is participating in any of the ISRA WC races and their practice sessions.

A driver is an entrant who has had her/his car passed in the technical inspection at the beginning of a race.

The Race direction is the responsible body for the ISRA WC event from start to end. The race direction relies on the Race Jury for rule interpretation. Only the Race direction can enforce penalties. Penalties can only be given to entrants.

An ISRA delegate is the representative of a country that has entrants, or has had entrants in an ISRA WC during the last 3 years. The delegates are obliged to participate in the ISRA delegates meetings and if elected be part of the Race Jury.

A driver's nationality is based on her/his valid passport. Only nations accepted within the United Nations are considered nations within ISRA.

1. General Principles

Every ISRA WC event must be organised and staged under the authority of the association of the ISRA Delegates.

ISRA WC events are presented in the spirit of promoting slot racing worldwide. An approved organiser of an event takes on this duty and is preparing and fulfilling an event as a promoter for their national association as well as ISRA as international organisation, and completely in line with the decisions made by the ISRA Delegates.

This also covers other associations approved by ISRA and listed below:

- European Slot Racing Association (ESRA) (2022).

Those countries wishing to stage the ISRA WC event must submit a written proposal to the acting ISRA chairman (see further 1.4).

Only those persons who are licensed by ISRA may take part in these events (see 1.10).

1.1 The ISRA Delegates, their meetings and the ISRA Officials

An ISRA delegate represents their country's license holders for a year. A delegate who abuses its position may be suspended if a driver represented by the delegate have made a complaint to the ISRA Chairman and the complaint has been found valid.

ISRA has four officials of which Chairman, Secretary and Technical officer are elected for three-year periods, and the Treasurer is elected until the ISRA Delegates decide otherwise. In case of any of the officials not being present at a WC event, substitutes shall be elected at the first Delegates meeting.

At the ISRA WC three ISRA delegates meetings shall be held. The ISRA officials prepare these meetings on times set in the event time schedule.

The ISRA Chairman or any of the ISRA Delegates may call for an e-meeting at any time between official Delegates meetings between WC events, however not more often than every three months. The Chairman will organise these meetings.

First ISRA Delegates Meeting

Held on the Saturday prior to the Production 24 race. This meeting shall decide on the following issues:

- A. The election of substitutes for absent officials.
- B. The election of a Race Jury for the event according to section 1.2 of the rulebook.

Second ISRA Delegates Meeting

Held on the Sunday evening. During the meeting the following issues shall be decided upon or presented:

- C. Submitted proposals for changes to the ISRA rulebook for the following year's event.
- D. Proposals of coming events.
- E. Other questions to be considered by the delegates.

Rule proposals and suggestions shall be submitted to the ISRA Chairman 30 days in advance of the ISRA WC event.

Issues brought up during the ISRA WC event may be discussed, but shall be decided following the procedure for an e-mail vote. This includes Race jury decisions made during the ISRA WC event.

Third ISRA Delegates Meeting

Held on the final day of the event (Saturday). At the meeting the following issues will be decided upon:

- F. Report from the last year's activities including financial report. This, including the financial standings past this year's event, shall be attached to the meeting minutes.
- G. Election of ISRA officials: ISRA chairman, ISRA secretary or ISRA technical officer, which depends on what position is up for election.
- H. Election of an election committee consisting of two delegates for the following year.
- I. Evaluation.
- J. Coming events.
- K. Changes to the ISRA rulebook for the following year's event.
- L. Voting on rule change proposals.
- M. Other questions.

Elections, voting and evaluation

The right to vote in the delegates meeting is only for delegates representing nations that have had participants for 3 years in a row at the ISRA WC.

Voting shall always be conducted by showing of hands.

A delegate cannot vote in an election in which he/she is a candidate.

The ISRA delegates can decide that a question brought up at the official meeting shall be decided through an email vote between the delegates. The chairman always conducts such a procedure. (See above for frequency.)

The election of officials is for three (3) years. The sequence is Chairman, Secretary, Technical officer starting from 2023 with the Chairman year 1, Secretary year 2, and Technical officer year 3. Each of these officials has an elected deputy. The election committee must present a proposal for a new official the latest 30 days prior to the Delegates meeting. Proposals from individual licensed drivers can be submitted directly to ISRA within the same time frame. A proposed person must know they are submitted and be approached by ISRA to be able to acknowledge if they are willing to take on the duty. The choice will be from these candidates.

To be selected a majority (50%) of votes is necessary. If none of the candidates receives 50% of the votes, the two with most votes enter a second voting round. In case of equal number of votes in the second round the Chairman of the meeting has a decisive vote.

Where there are conflicting rule proposals, to be passed a majority (50%) of votes is necessary. If none of the rule proposals receives 50% of the votes, the two with most votes enter a second voting round. In case of equal number of votes in the second round the Chairman of the meeting has a decisive vote.

The organiser of an ISRA WC shall always conduct an evaluation among the drivers during the championships. The results of the evaluation will be discussed at the third Delegates meeting the last day of the ISRA WC, and before the official closing of the event.

Minutes

The minutes from ISRA Delegate meetings will be published on the ISRA website (www.isra-slot.com) within 14 days from the meeting date.

All ISRA delegate votes shall be openly published in the meeting minutes.

1.2 The Race Jury

At the ISRA World Championships, the Race Jury will consist of the Race Director plus four (4) stewards (two voted by delegates + two chosen by the Race director.) and a deputy (chosen by the delegates). The jury will handle and solve all issues with regard to rule interpretation, disqualification, lap counter or track failures, etc. The Race Jury is called into duty by the Race director or the ISRA Chairman. A Deputy will step in if a Steward is personally involved in or affected by a dispute. A Deputy may also step in if a Steward is unavailable due to illness or else.

1.3 Race direction

A race direction must consist of a Race Director controlling the event (as a whole), two Race Controllers running the races, a Technical Director responsible for the technical inspections and the pit-area, and a Results Manager running the result services. The Race director may also serve as Technical director. These officials cannot be drivers at any stage of the event, the results manager exempted. If any of them is enrolled as a participant in a class, then, in that class, a non-racing deputy official must be appointed. The persons filling these positions must be presented on the official website 60 days prior to the event.

1.4 ISRA WC Organiser

An organiser of an ISRA WC is chosen by the ISRA delegates. The ratio between events in Europe and "overseas" is defined at 4:1. ISRA WC is organised in October.

A country may only submit one annual bid to host an ISRA WC – An internal vote within the country should occur (a vote based on racers with current ISRA points).

Submitted ISRA WC bids shall include track design layout, practice time information and proposed costs.

The chosen site for an event will be announced by ISRA at least two years in advance.

1.5 Participation

An "Olympic rule" is used which means that all nations are welcome to participate with entrants. ISRA observes the International Olympic Committee recommendations on eventual ban of nations/athletes (see 5. for temporary decisions).

1.6 Number of entries

The maximum number of drivers in ES32, F132 and ES24 is 120. Drivers will be accepted as follows if they are registered by close of registration (see 1.8).

1. Drivers with ISRA ranking points scored outside of their home country in order of ranking number.
2. Drivers with ISRA ranking points in order of ranking number.

3. Drivers with no ranking points in chronological order of registration.

If official entries in a class are below the maximum allowed for that class, the race organiser may, in conjunction with the ISRA Officials, allow further “wild card” entries into that class, up until practice starts for that class, providing that the entry or entries meet all the other relevant entrance criteria.

Any past ISRA world champion is welcome to race in the class they have won. No ranking points needed. They are prioritised among “wild cards” as a “WC wild card” also in other classes of the event. If a former world champion wants to participate and the entries exceed 120 in the class they won, this class will add an extra group extending the maximum to 128 entries in that class, thus open for more “wild cards”.

Every participating nation may present one person with no ranking points as a “wild card” entry. These “wild cards” will be picked first, but after “WC wild card”, to fill up the entry field in a class. If there are more “wild cards” than space, these “wild cards” will be prioritised before non-ranked persons registered. A “wild card” entry must be nominated by their ISRA delegate at time of registration. A “wild card” nomination can never make the entry total exceed 120 in a class. “WC wild card’s” will be ranked after all ranked drivers.

There is no restriction of the number of teams in the Production team race.

The organiser has to plan for a minimum number of 80 teams in the production team race, and 120 drivers in the sprint races. (See below for time schedule and steps to take if numbers exceed 80/120).

Due to concerns of the race duration the race direction may, together with the Race Jury, decide to alter the driving times in section 3.2 and 3.3.

Sample of time frame prepared for the 80 teams and 120 drivers in each class.

<i>Race Day</i>	<i>Time</i>	<i>Activity</i>	<i>Duration (*)</i>	<i>Note</i>
2 Friday	Production 1/24 team race (80 teams, 10 groups)			
	07.30 - 20.30	Practice	13 hours	2 Rounds of 8 x 4 min. Per Team
	07.30 -	Body, Tires and Motor Handout		
	Before Tech	1st ISRA Meeting	15 min.	
	19.45 - 21.15	Technical Inspection	1 hours 30 min.	(**)
3 Saturday	21.30 - 24.00	Qualification	2 hours 30 min.	
	07.30 - 20.00	Finals 8 x 7, 5 min.	12 hours 30 min.	10 finals (***)
	20.00 - 21.00	Track preparation	50 min.	
4 Sunday	20.15 - 21.45	2nd ISRA Meeting	1 hours 30 min.	
	Eurosport 1/32 Race (120 drivers, 15 groups)			
	07.00 - 18.00	Practice (8 x 4 min.)	11 hours	15 groups
	17.00 - 18.30	Technical Inspection	1 hours 30 min.	(**)

5 Monday	19.00 - 23.00	Qualification	4 hours	
	07.00 - 18.00	Heats 8 x 3 min.	11 hours	15 heats (***)
	18.10 - 18.40	Service Break	30 min.	
	18.20 - 18.50	Technical Inspection	30 min.	(**)
	19.00 - 21.45	Semi-finals 8 x 4 min.	2 hours 45 min.	
	21.55 - 22.25	Service Break	30 min.	
	22.15 - 22.30	Technical Inspection	30 min.	(**)
	22.40 - 23.40	Final 8 x 5 min.	1 hour	
6 Tuesday	23.50 -	Track preparation		
	Formula 1 1/32 Race (120 drivers, 15 groups)			
	07.00 - 18.00	Practice (8 x 4 min.)	11 hours	15 groups
7 Wednesday	17.00 - 18.30	Technical Inspection	1 hours 30 min.	(**)
	19.00 - 23.00	Qualification	4 hours	
	07.00 - 18.00	Heats 8 x 3 min.	11 hours	15 heats (***)
	18.10 - 18.40	Service Break	30 min.	
	18.20 - 18.50	Technical Inspection	30 min.	(**)
	19.00 - 21.45	Semi-finals 8 x 4 min.	2 hours 45 min.	
	21.55 - 22.25	Service Break	30 min.	
	22.15 - 22.30	Technical Inspection	30 min.	(**)
8 Thursday	22.40 - 23.40	Final 8 x 5 min.	1 hour	
	23.50 -	Track preparation		
	Eurosport 1/24 Race (120 drivers, 15 groups)			
	07.00 - 18.00	Practice (8 x 4 min.)	11 hours	15 groups
9 Friday	17.00 - 18.30	Technical Inspection	1 hours 30 min.	(**)
	19.00 - 23.00	Qualification	4 hours	
	08.00 - 19.00	Heats 8 x 3 min.	11 hours	15 heats (***)
10 Saturday	08.00 - 08.30	Service Break	30 min.	
	08.00 - 08.40	Technical Inspection	30 min.	(**)
	08.50 - 11.35	Semi-finals 8 x 4 min.	2 hours 45 min.	
	11.55 - 12.25	Service Break	30 min.	
	11.55 - 12.40	Technical Inspection	30 min.	(**)
	12.50 - 13.50	Final 8 x 5 min.	1 hour	
	15.00 - 17.00	3rd ISRA meeting		
	19.00 -	Race dinner and prize-giving		

(*) The addition of 8 teams (one full final) is 171 minutes (2h 51min) longer duration of the team race. The addition of 8 more drivers in a sprint race adds 96 minutes (1h 36 min) to the duration of the race.

(**) Tech is closed 20 minutes after final practice session seen group by group.

(***) The organiser is responsible for that the track is properly warmed up before the start of a morning heat. This has to be done with cars in race condition and of the same class raced. If the number of entries exceeds 120 the following take effect in steps until the schedule works out:

- A. Practice duration 3 minutes per lane (saves 2 hours per class)

- B. Semi-finals 3 minutes long. (saves 24 min per class)
- C. Production finals 8x5 minutes (saves approx 3 hours)
- D. No qualifying in Production 1/24 team race (saves approx 2 h 30 min)
- E. Number of practicing rounds cut from 8 to 4 (saves 5 hours per class)

1.7 Results and Broadcasting

ISRA WC events are broadcasted live with sound during racing.

An ISRA web application will be used to share results and daily updated race schedules.

Final results of a race will be presented by the Race direction or the Race jury after the 30 minutes protest time, but never later than 24 hours from the end of the last stage of the race.

1.8 Registration

The registration for a ISRA WC opens at April 1 and closes at June 30 for the year of the event. The complete registration process is hosted by ISRA on the ISRA Website.

Persons with a current ISRA ranking can register.

Persons without an ISRA ranking cannot register for the worlds by themselves. They need to be introduced by their national delegate (see list on the ISRA website). If no national delegate exists, they should contact an ISRA official (see contacts ISRA website) to receive an approval for signing up. An entrant with no prior ISRA ranking will be given a ranking number based on time of registration and the first registered is given the lowest number beyond drivers with ranking points.

1.9 Entry Fees

The maximum entry fee is Euro 35 per class.

The cost of the handout parts in the team race may not be higher than the parts' normal retail prices and not exceed a total set by the ISRA delegates (see section 5 Temporary rules).

The organiser must provide a detailed calculation of the handout parts to the ISRA officials. After approval of the ISRA officials the order can be placed.

It is the organisers responsibility to get money from registered racers. If you accept a subscription without being paid in advance, ISRA cannot be held responsible.

A participant who was registered and did not show on the ISRA WC event has to pay to the organiser the amount of the handout expenses. It must be paid before participating in another ISRA WC. There are only two exceptions: the participant cancels at least one month before the ISRA WC, or the participant cannot show due to illness (must be certified by medical doctor).

1.10 ISRA Driver's Licenses

A license number is required for taking part in any practice session. The total number of licenses granted worldwide is unrestricted.

The licence fee is to be paid together with the entry fees, and a license number be issued at registration.

The ISRA driver's license fee is Euro 10 per year.

1.11 ISRA Ranking Points

A person's ISRA ranking is based on the total of points the person has collected over the last three ISRA WC events as a driver.

The ISRA points are awarded on a falling scale as:

250-210-180-155-135-120-110-100-82-78-74-70-66-62-58-54 -50-47-44-41-38-35-32-29 (for the first 24 drivers). The 25th will receive 26 points, the 26th will receive 25 points, 27th will receive 24 points and so on down to 1 point for 50th. 51st will receive 0.97, 52nd 0.94 down to 0.55 for 65th place. 66th place will receive 0.53, 67th place will receive 0.51, and so on down to 0.25 for 80th. 0.24 for 81st, 0.23 for 82nd, and so on down to 0.01 for 104th place and those behind.

The top 8 qualifiers in the individual races receive bonus ISRA ranking points on a falling scale (15,12,10,8,6,4,2,1) to be added to their total from the race.

1.12 Trophies

Prizes are given to all finalists in the sprint races, and to all drivers in the top 8 teams in the production team race.

1.13 Racing Principles

Lane rotation is fixed as follows: 1 - 3 - 5 - 7 - 8 - 6 - 4 - 2 (Red - Green - Blue - Purple - Black - Yellow - Orange - White). Lane change is the driver's responsibility. No compensation can be given for incorrect changing of lanes.

If a problem with the track occurs, which requires the heat/race to be restarted, any driver who has worked on their car before the problem occurred and is ready before the heat/race was stopped, shall be allowed to start in the restarted heat/race. Drivers that have retired from the race and handed their cars over to the race direction are not allowed to restart even if the group should need to be re-run.

Only during the actual race time or qualifying, when track power is on, are drivers and/or their pit crew permitted to work on their cars. Changing tyres in qualifying or in the warm up in the heats is prohibited. During lane changes, drivers and/or their pit crews may change lane sticker, straighten the braids and body on the car and push in body pins.

A specific part of the track will be designated as the pit zone by race direction before the race starts. There shall be a minimum 3 meters of pit stop table, provided by the organiser, not close to the lap counter.

The driver is allowed to replace her/his car in front of her/him, if the car was picked up from there or else it has to be placed in the pit zone.

Any car damage that would make the car illegal, such as the loss of a major part of the body or a car dragging the track surface, must be immediately repaired during actual race time. The driver may continue a maximum of 3 laps before stopping to repair the car. An exception in Production 1/24, Eurosport 1/24 and Eurosport 1/32 is the loss of a front wheel(s) during the course of racing, and which must be repaired/replaced before the start of a new stage of the race. In Formula 1 1/32 the loss of a front wheel has to be repaired immediately.

During all stages of the race drivers and turn marshals in the ongoing group, and the race direction, may make track calls. If a stop is done in qualifying on the discretion of the Race direction due to a track fault the driver may choose to re-run their qualifying, thus losing any time made in the first attempt.

Race direction can temporarily stop the race due to:

- A. A car in a non-marshalable position (i.e.: in the middle of the straight in front of the drivers or on the in-fields),
- B. a car under a bridge or on the floor in any area,
- C. a car becoming a rider on another lane,
- D. and on the discretion of race direction for a track fault or issues in the venue.

The race direction must, before the race begins, point out which areas of the track that are considered under a) and b).

Drivers can call for a stop by no other word than "Track!" and only in situations and areas pointed out by the race direction before the race.

At a restart after a track call there should be a 3-2-1-go countdown.

Any driver that makes an illegal track call will be penalized, even if not running in the group (penalty see rule 1.15A). However, turn marshals are not seen as drivers when they are on duty. Still, they have to act as respectful drivers doing their job as marshals for their rivals, the sportsmanship rule is thus still valid (penalty see rule 1.15G).

Protest must be given with "protest fee" 100 EUR. Deadline for protests is 30 minutes after each stage.

1.14 Marshalling of Cars and Counting of Laps

All entrants in practice and all drivers in racing shall act as turn marshals. They marshal the group assigned by the Race direction following a set rotation. The marshalling rotation schemes are announced in the time schedule. In the case of a short number of marshals due to one less driver in a group, the Race direction shall select substitutes from the other groups in the same rotation. Acting as a marshal is personal. Missing turn marshalling duties renders in a penalty specified in section 1.15 B, C and D.

The number of marshals must be the same during the whole race.

Drivers, at the end of their group, must be the turn marshals in the next group. If the Heats are split, the marshalling shall also be split according to the split of the heats. Setup for marshalling is groups of three A-C, D-F etc. A marshals C, C marshals B and so on for all groups. The last group is made out of 4 groups if necessary.

The number of laps made can only be the result of the lap counter. No lap correction is made for missed counting due to the car's braids, nor lane jumping (rider) unless caused by a turn marshal placing the car on the wrong lane.

If a car falls off it must be placed back by a turn marshal where it is picked up, unless the car has fallen on the floor or in-fields then it shall be replaced where it initially left the slot, or if the car has slid over the lap-counter replaced 1 meter before the lap counter (see A and B below).

A racer can put their own car back in the slot following an accident on the main straight, however not violating the rules regarding where to place it.

Race direction must check the lap counting system if there is a sustained problem. The test is made through running across the counter a minimum of ten (10) laps with a test car always available to the race direction.

If a problem with the lap counter is detected, then upon its correction, the race direction must re-run the current segment. In case of a re-run Drivers will have their cars back only to change wheels and braids if the driver so wish.

Lap corrections are made for missed counting in the two following and explicit scenarios only:

- A. A car is a rider. The driver, a turn marshal or the race controller call "Track!". In the process of turning the power off the car passes the lap counter. Only if the turn marshalls closest to the lap counter and/or the race direction see the incident and review it as a missed lap, the car shall be placed before the lap counter.
- B. A car flies across the lap counter during a crash in the lap counter area. The driver, a turn marshal or the race controller call "Track!". Only if the turn marshalls closest to the lap counter and/or the race direction see the incident and review it as a missed lap, the car shall be placed before the lap counter.

1.15 Penalties

Distance penalties incurred in practice, tech or racing, should apply to the final race distance, not to qualifying.

- A. Illegal track call: - 2 laps.
- B. Missing marshalling duties in practice: Loss of the next practice session.
- C. Missing last marshalling duty in practice: Loss of the best qualifying time in sprint race or loss of 1 lap from the teams qualifying total (subsequently added to overall total laps) in the production team race.
- D. Missing marshalling duties in a race: - 10 laps.

- E. Accidental crash on the straight in front of the drivers, caused by a driver's hand or a car in hand, or a touch of another driver's car by a pit crew member while removing or replacing a car in the pit zone: - 10 laps. If it happens in another place of the track the penalty in k) below is added.
- F. A car returned to the enclosed park after the closing of technical inspection: - 10 laps.
- G. Unsportsmanlike conduct (late coming for marshalling, the use of obscene and foul language on any occasion constitutes examples of unsportsmanlike conduct):
 - a. For the first infraction: Warning,
 - b. for the second infraction: - 10 laps,
 - c. for the third infraction: Disqualification.
- H. Practising on another entrant's turn or driving another driver's car during racing is considered unsportsmanlike conduct. In the case of practising, it also renders in the loss of the entrant's next practice session. If it happens in the last practice round it will result in the entrant missing the best qualifying time in the sprint races and the loss of 1 lap in the production team race.
- I. Use of illegal parts, regardless of whether the car has passed a previous technical inspection: Disqualification.
- J. Driving with an illegal car: - 3 laps for every lap made from when the race controller recorded the car as illegal. When the car is repaired it must be re-teched before being returned to the track.
- K. A repaired car that is put on the track elsewhere than in the designated pit area: - 3 laps.
- L. Work on the car when track is off. Only cars involved in the accident may be worked on (only braids and body): - 3 laps
- M. Use of illegal chemical substance at all times: - 10 laps. The use of Metylsalicylat (Oil of Wintergreen) or any comparable chemical to improve the tire compound renders the driver a penalty of 10 laps in the ongoing stage, or, if found in a technical inspection, the following stage. In technical inspection this rests on smell and if the tires leave wet marks on the tech plate.
- N. Use of tools in lane changes or doing anything except changing lane sticker, pushing in body pins, straighten braids and body: - 10 laps.
- O. There must be only one driver/team per car and one car per driver/team during the race: Disqualification.

2 Track, Lap counter and Speed controllers

This section presents rules concerning the track and speed controllers for the ISRA WC organiser to abide.

2.1 Track

Each ISRA WC race must be run on a professionally built wooden track with 8 lanes, installed in a reasonable, comfortable and accessible place. Racers are not allowed to use personal steps (e.g. beer boxes). The organiser can provide purpose-built steps if found necessary.

- Safety arrangements, in the form of track sidewalls, must be used to prevent crash damages.
- A track must be at least 35 metres long (115 feet). The lane spacing (centre of slot to centre of slot) rule for ISRA WC tracks is a minimum of 115mm. The distance between

sidewalls and the outside lane must be a minimum of 150 mm (6 inches). Slot width must be 3-4 mm and slot depth at least 9 mm.

- Lanes must be signed with colours and/or numbers. Tracks shall have lane colours marked on top of the track with pin stripe line if colours are used.
- The track must have a flat surface. This should be measured by a 300 mm long level in two ways. First so that the banking angle is minimized (less than 5 degrees) by positioning the leveller in the direction of the radius, and second that joins and else is less than 1 mm from perfectly flat when measured with the 300 mm level held in the driving direction.
- Every ISRA WC track shall be re-braided within 12 months prior to the event.
- The track must be designed with a curved drivers' straight or curved/angled drivers panel to provide good visibility from all drivers' positions.
- A controllers' connection to the track must be made for 4 mm banana plugs as a standard for ISRA WC tracks coloured as follows: white (power), black (trigger), red (brake). National sockets are optional.

2.2 Track Wiring and Power

Track polarity on all ISRA tracks shall be standard, positive braid to the right in the direction of travel. The track wiring and the power supply must be capable of feeding continuous power of 150W per lane.

The cross section of track braid or rail must be 2,5 mm² (AWG 13) or more. The distance between supply cable points must not exceed 12 m (40 ft) (i.e. on a 45 meter track there must be at least 4 supply points on each lane). The cross section of supply cables must be 6 mm² (AWG 10) or more. All track braid joints must be secured with additional clamping, braid-braid butt contact is not sufficient.

Track voltage shall always be between 12.0 - 13.0 V DC (unloaded) and equal on the lanes. When loaded with 10A the track voltage must not drop more than 1V below the unloaded voltage as measured anywhere around the track and for all lanes.

Track voltage must be equal during all segments of a race (practice, qualifying, heats, semi-finals and final of a class). An indicator showing the voltage, must be accessible to all racers during the event.

For power supplies the following limits shall be obliged. If the track has a power supply for each lane, the devices must be identical. The capacity of a single power supply shared between the lanes must be at least 200 A. If shared supplies are used then the lanes must be fed from the supply individually by a minimum of 6 mm² cables on both positive and negative.

2.3 Lap Counter

An electronic lap counter system accurate to within 1/1000 of a second must be used. The track has to be divided into 100 equal sections that are easily readable. The lap counter must be in a position where the chance of cars passing outside of the slot is minimal. In case of need the Race Jury may decide to change the lap counter position. The lap counter position must be clearly visible to the Race Controller.

The lap counter area has to be marked on the track 1 meter before the lap counter till the end of the lap counter.

2.4 Speed Controllers

Speed controllers are unrestricted, but they must not raise or store voltage. This may be checked at any time during the event.

2.5 ISRA Control Principles

3 months prior to a ISRA WC one ISRA officer has to check with the organisers of the event that all technical specifications regarding track, wiring, power supplies and lap counter system are in line with what is specified in the ISRA rulebook.

At the start of the ISRA WC event, the ISRA technical officer together with the Race Jury and the Race Director will inspect all above mentioned aspects of the track. In case of that the inspection finds problems to be attended to, the organisers have to attend to them immediately.

3 Event Procedures

This section rules the organisation and running of an ISRA WC event.

A racer is responsible for his/her car, and that it is legal at all times, even if it was passed through technical inspection. Penalties may be imposed for cars found to be illegal during or after the race in post-technical inspection.

3.1 Prior to Race Procedures

An ISRA WC event consists of four classes run in the following sequence:

- Production 1/24 team race
- Eurosport 1/32 sprint race
- Formula 1 1/32 sprint race
- Eurosport 1/24 sprint race

The racing starts in the first Friday of the event and each class is run completely from start to end over two days, including practice, before the next class starts. Eurosport 1/24 is exempt as it runs into the final Saturday.

In line with section 1.5 Number of entries, a schedule is prepared by the organiser. The basic schedule for the 120 entries' limit is presented in section 1.6. When registration is closed and when the actual number of registered drivers is known an updated schedule is presented. A schedule must maintain as much practice time as possible.

3.1.1 Track Conditioning

The track must be cleaned and spray glued by the Race direction before the start of practice. A mixture of two (1 oz) bottles of medium glue into two litres of solvent shall be used. The mixture is prepared by the organizer under the supervision of the ISRA Technical officer. Application must be done only by spray glue in the turns and a maximum of one metre onto

a straight. Manufacture of glue will be proposed by the organizer and ratified by the ISRA Technical officer, then published in advance in the ISRA Rulebook "6. Local rules".

Only the race direction may modify the track condition, upon the authorisation of the Race Jury.

Drivers may clean the braid on their own lane at the beginning of a group for a period of 2 minutes designated by the race direction. Only drivers in the group are allowed to clean. Apart from this, car braid cleaning/conditioning liquids may never be used on the track except by the Track maintenance manager on instructions from the Race direction.

3.1.2 Practice

A "practice session" represents the minimum amount of practice that can be taken by one entrant at one time on a single lane. At the end of each practice session, that entrant must marshal the following practice session.

Pre-ISRA WC Practice

The organiser must announce in the invitation when the uncontrolled practice starts. It shall not start earlier than on the Monday four days before the beginning of the team race. Practice payment for the uncontrolled practice days will vary according to how many drivers are present. For 1-60 drivers €15 each, 61-80 drivers €12.50 each, for 81-100 drivers €10 each and 101-120 €7.50 each per day up to a maximum total of €60. The organiser must schedule a minimum of 8 hours for each practice day.

The practice days follow this order: PR24 and ES24 day 1, then ES32 and F132 day 2, and so on.

ISRA WC Practice

A generic system developed by ISRA to be used to display the schedule for practice on the notice boards. The heat number in practice has to be shown on a screen accessible to drivers.

A minimum of 30 minutes ticketed practice shall be run before each class between track preparation and start of the scheduled practice.

Before each class, the organiser must provide regulated practice. Practice is regulated, so that every entrant will have the same amount of practice time. Prior to the Production 1/24 team race a minimum of 2 rounds of 8 lanes of preferably 4 minutes each, and a minimum of 3 minutes each. Prior to each sprint race regulated practice has to be 1 round of 8 lanes of preferably 4 minutes each, and a minimum of 3 minutes. These practice sessions are scheduled, based on the ISRA Drivers' ranking. The length of each practice session will be the maximum duration possible as based on the number of entries (see section 1.7).

3.1.3 Enclosed Park and Technical Inspection

The Enclosed park (parc fermé) must be closed from everyone except the officials responsible for its function. It must provide for safe storage of the cars in order to avoid any possible damage to them. Drivers and the public must not at any time have access to the area. The organisers are responsible for the security of the area. Cars must remain in parc

fermé after the technical inspection, during the qualifying session and during every stage of the racing.

The Race Director or another appointed person must be present at the technical inspection, at all times, to see that rules are followed. This person is also responsible for making sure that cars are at the technical inspection within the given time.

Technical inspection shall be carried out accurately. A specification sheet with checkboxes must be used to make sure all items are checked.

People who are doing the technical inspection must be properly taught to do it by the ISRA officials. An orientation is to be conducted before the tech starts.

For qualifying, all cars must be brought to the technical inspection impound during the announced open period of time for each class. A technical inspection of the cars based on all eligible rules will begin at the start of that period. This period ends 20 minutes past each practice group's last practice session. All non-legal cars will be returned to the entrants to be fixed, and can be re-presented to the technical inspection anytime within the tech period for their group. All non-legal cars at the closing of a group's technical inspection period, will be released for 5 minutes to be adjusted once technical inspection is closed. Cars deemed illegal by the end of that period will be technically inspected during race time and if passed the entrant becomes a driver. All legal cars will be marked by the technical inspectors (engraving on chassis and stamp on body) and be ready to qualify. Once a group has completed tech, qualifying should commence as soon as possible.

It is permitted for a driver in ES 32, F1 32 & ES 24 to practice with a practice car after his/her race car has been put into parc fermé for technical inspection before qualifying.

It is not permitted to use a practice car during the service breaks for the semi-finals or final. The service breaks between the heats and the semi-finals, and between the semi-finals and the final, have the duration of 30 minutes. The track has its power turned on during the breaks. The technical inspection is open during the service break. All cars have to be on the technical inspection table by the latest at the end of the 30 minutes period. All legal cars will be deemed ready to continue racing. All non-legal cars will be returned to the drivers if time is still available. These drivers will be given to the end of the service break to make their cars legal.

A car that has been found faulty in the technical inspection may be repaired during the warm up. The car must be re-checked after the repair during the warm-up or after the start, but before making any race laps. A technical inspector must be available at the starting line for the car(s) to be checked as quickly as possible. While the repairing of a faulty car must not delay the start of the race, the inspection may be fulfilled during the start process.

Cars may be randomly checked at any time in a segment. Any part of the car that deviates from the dimensional rule limits must be repaired during actual race time. Those dimensions are: a) wheel width, b) overall car width, and c) rear car height. In the Production 24 team race all cars will be re-inspected after their heat. The following points are checked: a)

blueprint on motor (the motor may be opened), b) the stamp on the body, c) the blueprint and rubber of the tires, d) the engraving of and intentional structural changes made to the chassis. Any tampering found results in the disqualification of the drivers of the team regardless of if the car has passed an earlier inspection during the race.

Cars that have had their body, tires or gear changed during racing shall always have its dimensions (widths and heights) checked in the next lane change following the repairs. The technical check shall not inflict on the driver's lane change time. If the width or height is illegal it has to be repaired immediately, but during racing time.

ISRA calibrated tools must be available to drivers at all times. Rear height in all classes, and the measure between ground and bottom of bumper in Production 24, are measured on a recessed (guide and rear wheels), non-magnetic tech block.

3.2 Production 1/24 Race Procedure

All handout parts shall be marked by the organizer in a manner approved by the ISRA Technical Officer. This includes chassis, bodies, motor, tires, interior and any other handout parts. At the start of the ISRA WC event, the ISRA Technical officer together with the Race Jury and the Race Director will inspect the fulfilments of seals and stamps to prevent tampering of the hand-out parts.

The marked parts will be packed in individual boxes, the boxes will then be numbered. The teams will pick random numbers from hat and the related boxes will be given out. If the parts are marked with numbers, the boxes are numbered without any numbers being visible to the entrant. The teams will pick a random box and the related number be registered.

When the handout parts are issued to the teams, the selection should be done in front of the racer.

The race shall run as two stages: qualifying and groups.

3.2.1 Team/Driver Seeding

The production race is a 2-person team race, with each team member driving equal amounts.

The ranking of the teams is based on the ISRA drivers' ranking. The best ranking of the two drivers is used.

3.2.2 Qualifying

Qualifying is run over 1 minute where the team with the longest distance covered wins. Each member of a team must drive 30 seconds. A 15 second stop for driver change is provided.

The qualifying starts with the team with highest ranking number, then the next highest and so on.

3.2.3 Racing

There is no warm up prior to race start in the Production 24 team race.

Each group consists of 8 segments. Each segment is 7.5 minutes. If possible, the number of teams in each group should be equal. If not, the number of teams can be one less in the first few groups.

The teams qualified at positions 1 to 8 will race in the last heat, drivers qualified at positions 9 to 16 in the second last heat, and so on. If possible, the number of teams in each heat shall be equal. If not, the number of teams can be one less in the first few groups.

The starting lane is determined by the qualifying order, with the best in a group starting on lane 1 (red).

After each group, a team's finishing position will be a result of the sum of the laps completed, the last lap sections and the result from qualifying. In the event of a tie the number of race laps including track sections of the last lap shall decide.

3.3 Sprint Race Procedure

Sprint races are conducted in the following classes: Eurosport 1/32; Formula 1 1/32 and Eurosport 1/24. All sprint races consist of four stages: qualifying, heats, semi-finals and a final.

3.3.1 Qualifying (Stage 1)

Qualifying is the first stage of a race. It will be for one minute per driver, on a qualifying lane as chosen by the race direction. The qualifying order is based on the ISRA Drivers ranking. In all sprint classes, the best ranked drivers will qualify last. The overall qualifying results are determined by the best single lap time as attained by each driver. For two drivers having matching lap times, their second-best time will break the tie. Every driver, who misses his or her qualifying time, will be classed in the last position.

A driver may check and straighten the braids while on deck, however the car has to be placed on the track by an official.

All drivers will be placed into stage 2, heats, sorted by their qualifying result.

3.3.2 Racing (Stage 2 - 4)

Stage 2, heats, is driven 8x3 minutes. The racers qualified at positions 1 to 8 will race in the last heat, drivers qualified at positions 9 to 16 in the second last heat, and so on. If possible, the number of drivers in each heat shall be equal. If not, the number of drivers can be one less in the first few groups.

Stage 3, semi-finals, is driven 8x4 minutes. The best 24 drivers (by lap total) from stage 2 will be placed into 3 semi-finals (A, B and C). The top 8 will be placed in semi A, the next eight will be placed in semi B and the remaining 8 in semi C, which is run first, followed by B and A.

Stage 4, final, is driven 8x5 minutes: The best 8 drivers (by lap total) from stage 3 will move in to the final.

Starting lanes in stage 2 (heats) are set according to qualification results with the best in a group starting on lane 1 (red). In stage 3 (semi-finals) and stage 4 (final) the starting lanes are

selected by the racers in an order determined by the results from stages 2 & 3. Best result gets first choice.

Move up in case of a matching lap and segment total is always decided by the better result in the previous stage of the race, going back until the tie is resolved.

Depending on the number of drivers, the length of the stages may change to fit reasonable race duration, as determined by the Race direction.

Leading up to the first segment of each stage a 1-minute warm-up shall be run on the starting lane. During warm-up it is not allowed to change tires.

4 Technical Specifications

This section regards all technical specifications to be scrutinised during technical inspection. They are presented class by class. All dimensions are in millimetres (mm).

Only one guide flag device per car is allowed.

In case of delivery problems of bodies, ISRA will announce an alternative body at the latest 60 days prior to the ISRA WC event.

4.1 Production 1/24

4.1.1 Dimensions

Car	Measurement in mm
Max height at rear wing	35
Max width excluding body pins and tape	83
Max height from track surface to bottom of bumper	12,7
Min vertical edge at front	1
Min ground clearance under rear axle and between rear tires	0,8
Wheels and Axles	
Max rear tire width	20,7
Min rear axle diameter	2,36
Min distance from top of rear axle to bottom of chassis	8,6
Min front wheel diameter	12,7
Min front wheel width	0,8
Min front axle diameter	1
Min front wheel track	72
Chassis	
Max length measured between centres of rear axle and guide pivot	120
Max length of Guide flag	28,5

4.1.2 Chassis

The following chassis are permitted by ISRA in their approved shape and structure:

- Champion (USA) 420 Turbo Flex
- Parma (USA) 595 Flexi 2
- JK (USA) JK X25
- JK (USA) JK C43

All the chassis used for handout at an ISRA WC event must be from the same batch.

Production chassis shall be completely stamped. It is allowed to clean, but not allowed to grind, sand or polish the chassis. The following modifications are allowed:

- Lead may be taped or glued to the top of the chassis.
- Tape may be added to the top of the chassis.
- The front axle may be soldered to the chassis. The front axle shall be omitted if sticker fronts are used.
- Front wheel retainers may be soldered to the front axle.
- Pin Tubes may be added in the original body mounting holes and be either floating or fixed to the chassis.
- Rear oilites may be soldered to the chassis.
- On all chassis except the JK X25 and JK C43 the motor may be soldered to the chassis using a tube/wire placed on the rear axle side of the motor, however it must be mounted below the rear axle.
On the JK X25 and C43 only the supplied motor brace shall be used.
- Thickness of JK X25 chassis bite-bar must be from 1.1 to 1.4 mm and may be shaped as per the diagram below.

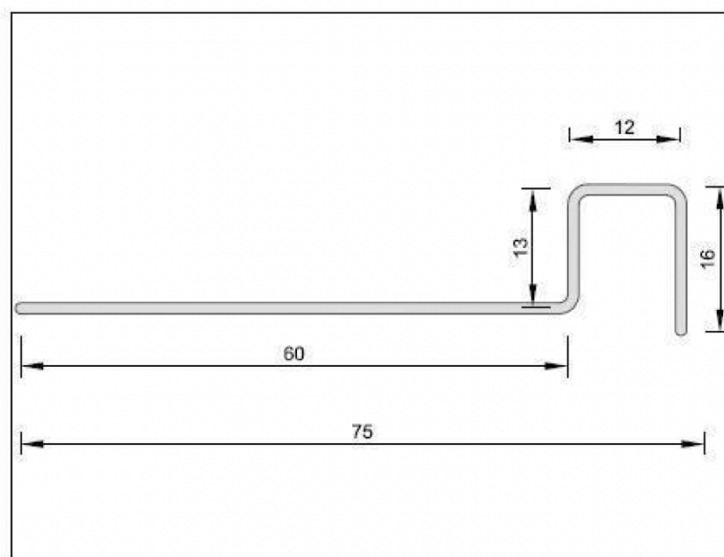

- Only original JK manufactured "J" bite-bars of thickness 0.8mm to 1.2mm shall be used JK C 43 chassis.

4.1.3 Body

Production body make and model is chosen by organiser and approved by the ISRA Technical officer.

The body must be mounted as intended and cover the chassis, including the rear tires and the guide flag, in at least one unforced position. It can be fixed to the chassis with pins, clips and/or sellotape. Body decoration is unrestricted, but must be made in at least two different colours. The body must be completely opaque. Windows must be left clear and all four wheels must be completely visible when viewed from the side. The best ranked driver's license number must be displayed in at least 3 different positions. Numbers must be performed as a sticker; minimum size shall be 7mm. Handwritten numbers are not allowed. All cars must have the hand-out interior in the original cockpit position and block any view of the chassis seen from above.

Body cutting must be defined by organiser in section 6. Local rules.

The organiser hands out two bodies to each team. Only one body may be checked in for the race.

4.1.4 Motor

The motor is a sealed handout Group 12 motor and is to be used as supplied. However, the motor shaft may be shortened and the can and magnet may be ground to provide axle clearance.

Specifications for the organiser and the ISRA Technical officer:

- A production motor must be built for endurance racing.
- The motors must be handed out with the can screws and the brush springs sealed to prevent tampering.
- The organiser must check all motors before the hand-out procedure starts to make sure they are built properly.

1. Can & Endbell

Any commercially available "C" Can and Plastic Endbell. Inside can dimensions are defined as not less than:

Length - 23.50 mm / Width - 21.21 mm / Height - 14.22 mm

The can bearing must be a ball-bearing, endbell bearing free choice. Endbell must be secured to the can by means of screws.

2. Brushes, Springs

Brush hoods must be secured to brush plates by either adhesive or soldering. Brush hoods must allow a minimum of 3mm wear.

Brushes must be shunted.

Brushes must be of premium quality (BF11 or Gold Dust). Springs must be of good quality from a recognized manufacturer. Springs must be insulated.

3. Magnets

Magnet dimensions plus or minus 10%:

Length: 12.70 mm / Height: 13.97 mm.

Magnets must be commercially available and of single ceramic type.

Magnets must be securely glued into the can using Skinner or similar adhesive.

4. Armature

Minimum \varnothing 13.03mm / Maximum \varnothing 13.16mm / Minimum stack length 8.89mm / Wire Size 29 AWG. Turns per pole 50. Max. timing 45 degrees.

Arms should be just tagged as 12's and no special ISRA tag.

Must have drill blank or better hardened shaft.

4.1.5 Front Wheels and Axle

The front axle must be straight and pass through the original hole as intended by the manufacturer. The front wheels must be mounted to the axle, turn on their centre at a 90 degrees angle to the track surface, and have a black rubber/plastic perimeter.

Stickers may be used instead as front wheels. Stickers must be placed in correct front wheel positions on the body.

4.1.6 Rear Tires, Rear Axle, Bushings and Gears

Handout tires are used. In case of damage to handout tires during practice or due to truing mistakes it is possible to buy max. 2 extra pairs of racing tires for the race. Damaged marked tires must be returned to organiser.

The rear axle must run in oilites.

Gears fixed to the axle by means of adhesive are not permitted.

Only plain steel non hollow axles are allowed.

4.2 Eurosport 1/32

4.2.1 Dimensions

Car	Measurement in mm
Max height at rear wing	32,5
Max width excluding body pins and tape	64
Min ground clearance under rear axle and between rear tires	0,8
Wheels and Axles	
Max rear tire width	16
Min rear tire diameter	15
Min front wheel diameter	12,7
Min front wheel width	0,8
Min front wheel track	56
Chassis	
Max length measured between centres of rear axle and guide pivot	105
Max length of Guide flag	28,5

4.2.2 Chassis

No restrictions.

4.2.3 Body

Eurosport 1/32 is a single body class. Legal body for 2023-2025 is Redfox Audi R10.

The body must not deviate from its shape as produced by the manufacturer. The body must cover the entire chassis, including the rear axle and guide flag, in at least one unforced position. It can be fixed to the chassis with pins and/or sellotape.

Body decoration is unrestricted, but must be made in at least two different colours. The body must be completely opaque. Windows must be left clear. The driver's license number must be displayed in at least 3 different positions. Numbers must be performed as a sticker or painted in decal quality; minimum size shall be 7mm. Handwritten numbers not allowed.

All cars must contain a painted and 1/32 scale three-dimensional interior with the driver's helmet, shoulders, arms and steering wheel mounted in the original cockpit position. No portion of the chassis must be seen through the cockpit area when viewed from above. Body cutting must maintain every detail of the real car (i.e. lights, wheel position, etc.).

Two bodies per car are permitted, provided that they are painted, trimmed and mounted identically. The extra body is kept in the parc fermé and made available on the return of the other. During a service break both bodies are available to the driver.

4.2.4 Motor

No restrictions.

4.2.5 Front Wheels

The front wheels must turn on their centre at 90 degrees angle to the track surface and have a black rubber/plastic perimeter. Front wheels must be completely visible when viewed from the side.

Stickers may be used instead as front wheels. Stickers must be placed in correct body positions on the body.

4.2.6 Rear Tires

The rubber portion of the tire contacting the track surface must be black. Rear tires must be completely visible when viewed from the side.

4.3 Formula 1 1/32

4.3.1 Dimensions

Car	Measurement in mm
Max height at rear wing	30
Max width excluding body pins and tape	68
Min ground clearance under rear axle and between rear tires	0,8

Min ground clearance under front wheel support/axle	0,8
Min left of rear wing endplate/sidepod (see illustration below)	12
Wheels and Axles	
Max rear tire width	16
Min rear tire diameter	15
Min front wheel diameter	14
Min front wheel width	4
Min front wheel track	62
Chassis	
Max length measured between centres of rear axle and guide pivot	105
Max width of chassis pan section between pans	52
Max length of pans	68
Max width in front pans, excl. Front wheel supports	34
Max width behind pans, incl. Rear axle supports	34
Max length of Guide flag	28,5

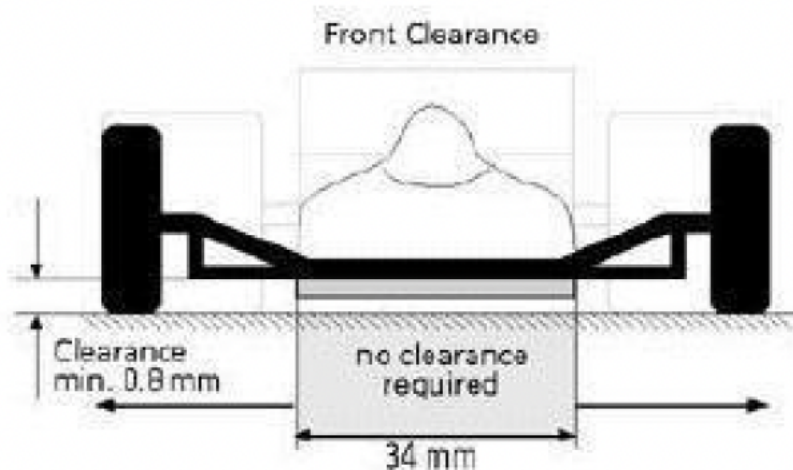

4.3.2 Chassis

Chassis are unrestricted except for the following limitations: The motor must be mounted in the chassis in the "in-line" position (i.e. in a 90-degree angle to the rear axle).

4.3.3 Body

Formula 1 1/32 is a single body class. Legal body for 2023 - 2026 is Red Fox Ferrari.

The body must not deviate from its shape as produced by the manufacturer. It can be fixed to the chassis with pins and/or sellotape.

The paint scheme must represent an actual F1-team's car from 1990 to date. Pearl, fluorescent and metallic paints are only allowed if actually a part of an original paint scheme. The major engine cover and sidepod sponsors logo/name must be present. The body must

be completely opaque and cover the entire chassis including the guide flag, in at least one unforced position. Excepted are axles, wheels, and the support(s) for the front axle. An additional exception is the rearward portion of the chassis' pans not covered by the body. The driver's license number must be displayed in 3 positions: on both sides of the rear wing and on the front of the car. Numbers must be performed as a sticker or painted in decal quality; minimum size shall be 7mm. Handwritten numbers not allowed.

All cars must contain a painted and 1/32 scale three-dimensional interior with the driver's helmet, shoulders, arms and steering wheel mounted in the original cockpit position. No portion of the chassis must be seen through the driver area when viewed from above.

Body cutting must maintain every detail of the real car (i.e. wheel position, etc.). Pinstriping and bodyline detailing is mandatory.

Two bodies per car are permitted, provided that they are painted, trimmed and mounted identically. The extra body is kept in the parc fermé and made available on the return of the other. During a service break both bodies are available to the driver.

Below is a drawing illustrating the accepted cutting line of the rear wing (greyed area), and where to position the scale logos and driver's ISRA license numbers at the rear.

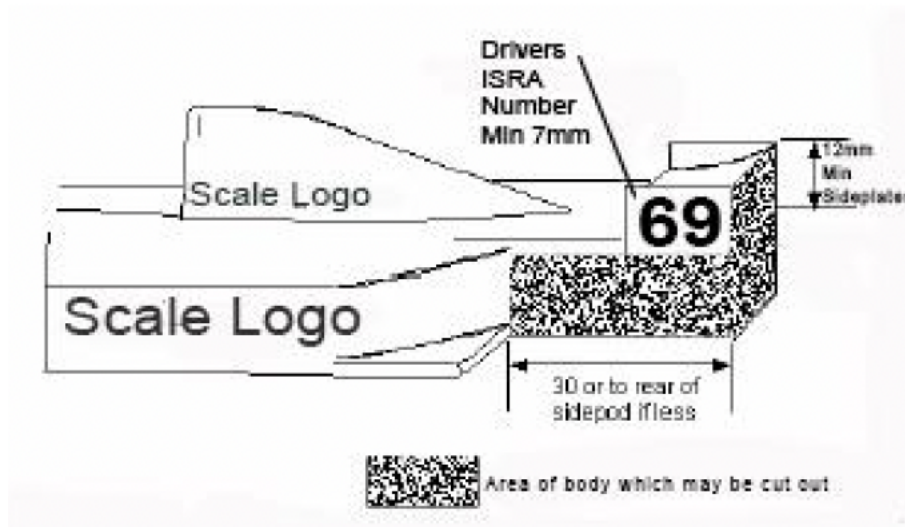

4.3.4 Motor

No restrictions.

4.3.5 Front Wheels

They must turn on their centre at 90 (+/- 5 degrees) to the track surface and have a black rubber/plastic perimeter. The front wheels and their supports must be in the intended position for the approved body used.

4.3.6 Rear Tires

The rubber portion of the tire in contact with the track surface must be black.

4.4 Eurosport 1/24

4.4.1 Dimensions

Car	Measurement in mm
Max height at rear wing	35
Max width excluding body pins and tape	83
Min ground clearance under rear axle and between rear tires	0,8
Wheels and Axles	
Max rear tire width	20,7
Min rear tire diameter	16
Min front wheel diameter	12,7
Min front wheel width	0,8
Min front wheel track	56
Chassis	
Max length measured between centers of rear axle and guide pivot	125
Max length of Guide flag	28,5

4.4.2 Chassis

No restrictions.

4.4.3 Body

Eurosport 1/24 is a single body class. Legal body for 2019 - 2024 is RedFox (Brazil) RedFox Audi R10ISRA Long.

The body must not deviate from its shape as produced by the manufacturer. The body must cover the entire chassis, including the rear axle and guide flag, in at least one unforced position. It can be fixed to the chassis with pins and/or sellotape.

Body decoration is unrestricted, but must be made in at least two different colours. The body must be completely opaque. Windows must be left clear. The driver's licence number must be displayed in at least 3 different positions. Numbers must be performed as a sticker or painted in decal quality; minimum size shall be 7mm. Handwritten numbers not allowed.

All cars must contain a painted and 1/24 scale three-dimensional interior with the driver's helmet, shoulders, arms and steering wheel mounted in the original cockpit position. No portion of the chassis must be seen through the cockpit area when viewed from above. Body cutting must maintain every detail of the real car (i.e. lights, wheel position, etc.).

Two bodies per car are permitted, provided that they are painted, trimmed and mounted identically. The extra body is kept in the enclosed park and made available on the return of the other. During a service break both bodies are available to the driver.

4.4.4 Motor

No restrictions.

4.4.5 Front Wheels

The front wheels must turn on their centre at 90 degrees angle to the track surface and have a black rubber/plastic perimeter. Front wheels must be completely visible when viewed from the side.

Stickers may be used instead as front wheels. Stickers must be placed in correct front wheel positions on the body.

4.4.6 Rear Tires

The rubber portion of the tire contacting the track surface must be black. Rear tires must be completely visible when viewed from the side.

4.5 New products for approval

New products for approval must be submitted to the ISRA Technical officer by December 31st for consideration at the following years meeting.

5 Temporary rules

This section concerns decisions with a temporary character and are valid until the ISRA Delegates decide otherwise or the furthest until the next official ISRA WC event and its ISRA Delegates' meetings.

- o Due to international sanctions against Russia and Belarus, mandated parts such as bodysells, manufactured in those countries, are not allowed at the ISRA WC event 2023. Likewise, race control systems manufactured in those countries are prohibited.
- o Due to a specific decision by the delegates to void the "Olympic rule" (rule 1.5), Russian and Belarusian driver entries are banned for the ISRA WC event 2023.
- o Total cost for handout parts for 2023 is maximum €250.

6 Local Rules and Organiser Responsibility

The organiser must ensure the following:

- That there is a minimum light reading of 300 LUX at the track surface.
- Equal pit spaces, with power outlets for all drivers, with sufficient space between benches for access, Minimum 120cm space between tables in pits.
- There must be blinds in place to ensure that sunlight does not shine on the track.
- There must be good sound and visual communication between the track room and any remote pit areas.
- Fulfill all requirements set out in the rulebook.

Basic information

- o Date
- o Race venue
- o Address, GPS coordinates, map
- o Track

- o Web sites, registration info
- o Accommodation
- o Contacts

Production race handouts

- o Body model and cutting rules
- o Motor producer
- o Tyres

Race direction

The race direction will consist of the following persons:

- General manager:
- Race Director:
- Race Controller:
- Technical Inspection:
- Track Management:
- Web & Information:
- Results manager:
- Venue Management:

The persons filling these positions must be presented on the official website 60 days prior to the event.

Conduct

- o Additional information (i.e. smoking and alcohol rules).